

Superreel® - Industrial Reel

AMSC500D SERIES



FEATURES

- To handle live electric cable/cord.
- Crank rewind. Power rewind available, consult factory.
- Silver alloy slip ring. Heavy current, Heavy duty.
- Durable abrasion and corrosion resistant baked-on power coat finish.
- Rugged construction: Steel drum and all bolted construction. Vibration-proof self-locking fasteners.
- Safe: adjustable spool rotation drag eliminates cord backlash when de-reeling. Lock pin prevents spool rotation when reel is not in use.
- Low maintenance: Dual main bearings never need lubrication.
- Compact for critical space requirements.
- Shipped completely assembled, ready to install.

1



WWW.SUPERREEL.COM

Email: sales@superreel.com

Superreel® - Industrial Reel

DIMENSIONS

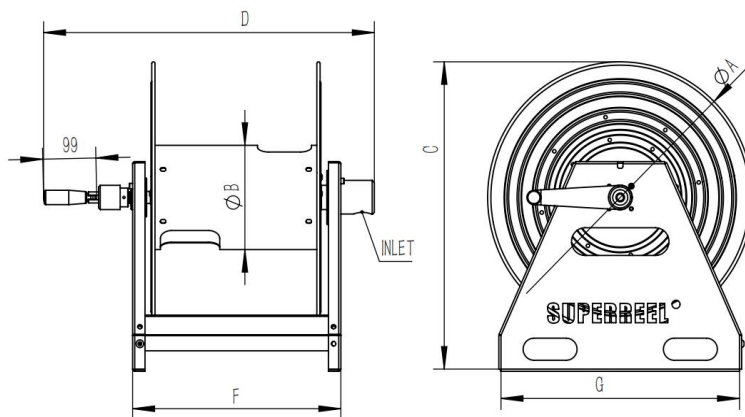

P/N	Port&core number	HOSE-ID. or CABLE-square	Pressure or lmax	Working Length	Reel inlet	Hose outlet	A	B	C	D	E	F	G	H	I	J	K
AMSC500D1205010060	12	1.5 ²	10A	60	Bare wire	Bare wire	475	189	560	613	475	386	442	359	320	4	11
AMSC500D0505050060	5	6 ²	50A	60	Bare wire	Bare wire	475	189	560	613	475	386	442	359	320	4	11
AMSC500D0405065060	4	10 ²	65A	60	Bare wire	Bare wire	475	189	560	613	475	386	442	359	320	4	11
AMSC500D0405091050	4	16 ²	91A	50	Bare wire	Bare wire	475	189	560	613	475	386	442	359	320	4	11
AMSC500D0405012040	4	25 ²	120A	40	Bare wire	Bare wire	475	189	560	613	475	386	442	359	320	4	11
							Dimensions are in millimeters										

