

# Superreel® - Industrial Reel

## ASTH370D SERIES



## FEATURES

- Dual pedestal, heavy duty. Reel frame, spool and drum are fabricated of heavy gauge steel.
- Full flow shaft swivels. Double-sealed, "O" rings prevent leakage.
- Anti-lockout design: Ratchet prevents lockup when hose is fully extended, eliminating the need to manually release the pawl at the reel.
- Superior performance: Swivel and reel ball bearings reduce torque load on power spring for smooth retraction and durability.
- Corrosion resistant: Sealed bearings prevent contamination and minimize maintenance.
- Easy installation and maintenance: Factory lubricated one-piece power spring cassette make installation safer and maintenance easier.
- Adjustable and Versatile: Guide arm adjust to wall, floor, vehicle, overhead positions. Narrow design allows for maximum use of available space.



**WWW.SUPERREEL.COM**

Email: [sales@superreel.com](mailto:sales@superreel.com)

# Superreel® - Industrial Reel

## DIMENSIONS

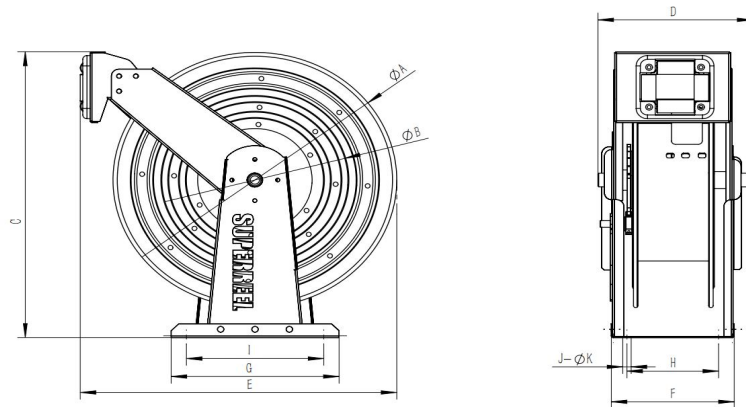

P/N	Port&core number	HOSE-ID. or CABLE-square	Pressure or lmax	Working length	Reel inlet	Hose outlet	A	B	C	D	E	F	G	H	I	J	K
ASTH370D0201016008	2	1/4"	1.6Mpa	8m	BSPT1/4".F	BSPT1/4".M	370	230	416	203	415	161	220	120	180	4	9
ASTH370D0202016008	2	5/16"	1.6Mpa	8m	BSPT3/8".F	BSPT3/8".M	370	230	416	203	415	161	220	120	180	4	9
ASTH370D0203016008	2	3/8"	1.6Mpa	8m	BSPT3/8".F	BSPT3/8".M	370	230	416	203	415	161	220	120	180	4	9
							Dimensions are in millimeters										

