

Superreel® - Industrial Reel

AMSH280S SERIES



FEATURES

- Lighter-duty. All-steel construction. Durable powder coat finish.
- Full flow shaft and swivel
- Rugged construction: Steel drum and all bolted construction. Vibration-proof self-locking fasteners.
- Safe: adjustable spool rotation drag eliminates hose backlash when de-reeling. Lock pin prevents spool rotation when reel is not in use.
- Low maintenance: Dual main bearings never need lubrication.
- Shipped completely assembled, ready to install.



Superreel® - Industrial Reel

DIMENSIONS

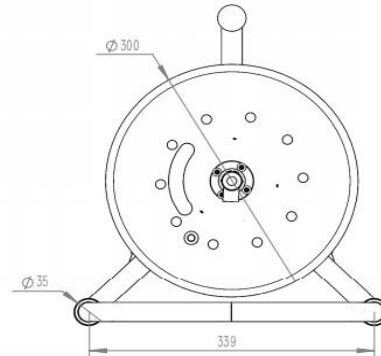
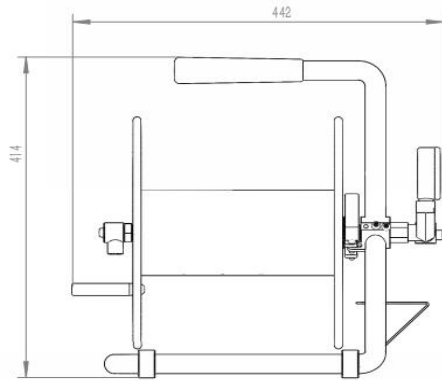

P/N	Port&core number	HOSE-ID. or CABLE-square	Pressure or I _{max}	Working length	Reel inlet	Hose outlet	A	B	C	D	E	F	G	H	I	J	K
AMSH280S0101160015	1	1/4"	16Mpa	15m	BSPT1/4".F	BSPT1/4".M	300	110	414	442	375	400	375	/	/	/	/
AMSH280S0103160015	1	3/8"	16Mpa	15m	BSPT3/8".F	BSPT1/2".M	290	165	379	206	300	150	260	120	220	4	9
Suitable for super flexible hose							Dimensions are in millimeters										

