

Superreel® - Industrial Reel

ASSH580D SERIES



FEATURES

- Dual pedestal, heavy duty. External spring design, easy to change a new Spring to extended service life.
- Reel drive springs manufactured from high-quality, scaleless blue tempered steel.
- Anti-lockout design: Ratchet prevents lockup when hose is fully extended, eliminating the need to manually release the pawl at the reel.
- Superior performance: Swivel and reel ball bearings reduce torque load on power spring for smooth retraction and durability.
- Corrosion resistant: Sealed bearings prevent contamination and minimize maintenance.
- Easy installation and maintenance: Factory lubricated one-piece power spring cassette make installation safer and maintenance easier.



Superreel® - Industrial Reel

- Adjustable and Versatile: Guide arm adjust to wall, floor, vehicle, overhead positions.

Narrow design allows for maximum use of available space.

DIMENSIONS

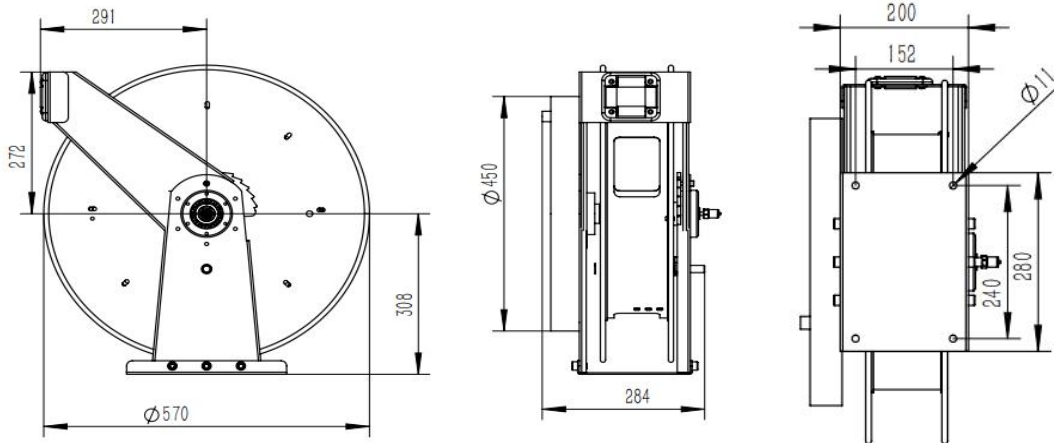

P/N	Port&core number	HOSE-ID. or CABLE-square	Pressure or lmax	Working length	Reel inlet	Hose outlet	A	B	C	D	E	F	G	H	I	J	K
ASSH580D0103200030	1	3/8"	20Mpa	30m	BSPT3/8".F	BSPT3/8".M	570	400	593	284	576	200	280	152	240	4	11
External spring design							Dimensions are in millimeters										

